



Available online freely at [www.isisn.org](http://www.isisn.org)

# Bioscience Research

Print ISSN: 1811-9506 Online ISSN: 2218-3973

Journal by Innovative Scientific Information & Services Network



RESEARCH ARTICLE

BIOSCIENCE RESEARCH, 2019 16(2): 1913-1924.

OPEN ACCESS

## *In vitro* synthetic seed and herbicide resistant sugar beet varieties (*Beta vulgaris* L.)

Mohamed I. Masri<sup>1</sup>, Roba M. Ismail<sup>2</sup>, Wessam M. Rslan<sup>2\*</sup> and Naglaa A. Abdallah<sup>3</sup>

<sup>1</sup>Agronomy Department, Faculty of Agriculture, Cairo University, Cairo, **Egypt**

<sup>2</sup>Gene Transfer Lab, Plant Genetic Transformation Department, Agricultural Genetic Engineering Research Institute, Agricultural Research Center, Giza, **Egypt**

<sup>3</sup>Genetic Department, Faculty of Agriculture, Cairo University, Cairo, **Egypt**.

\*Correspondence: [wessam.raslan@ageri.sci.eg](mailto:wessam.raslan@ageri.sci.eg) Accepted: 21 May 2019 Published online: 04 June, 2019

This work was carried out to get synthetic seed and herbicide resistant sugar beet genotypes, using micro-shoot tips encapsulated in 4% (w/v) sodium alginate with 100 mM Ca (NO<sub>3</sub>) 24H<sub>2</sub>O as complex solution. Two solutions were evaluated for their encapsulated vitality efficiency SA1 solution (MS, 3% sucrose, 4% sodium alginate, 2% sorbitol and 2% mannitol) and SA2 solution (MS, 3% sucrose, 1.3 BAP+4% sodium alginate, 2% sorbitol and 2% mannitol). Synthetic seeds were kept in the dark at 4°C to slow down all the tissues growth and stored for different time ranging from 1 week to 8 weeks. Synthetic seeds from different conditions were evaluated for their vitality by germinating on two different media (SA1 and SA2) the results showed that SA2 was more efficiency on encapsulated re-growth. For transformation shoot tips of El-Magary and Farida cultivars were used using agrobacterium carrying the plant vector PISV 2678. Two methods carried out to select Bialaphos resistant plantlets, culture explants on media containing Bialaphos (3.5 and 4mg/l) for El-Magary and Farida respectively. The other method was carried out to select Bialaphos resistant plantlets with bar gene using PCR and leaf painting test. Results showed that El-Magary has higher transformation efficiency (18%) than Farida (12%). Genetic stability of encapsulated plants was carried out using RAPD-PCR analysis, no significant variability were observed between encapsulated and control plants. Applying this technique can be recommended for developing synthetic seeds as cost effective and time saving method.

**Keywords:** Sugar beet, Artificial seeds, Storage ability, Agrobacterium, Transformation, Basta, and Bialaphos.

### INTRODUCTION

Sugar beet (*Beta vulgaris*) is one of important resources of sucrose production among crops and provides about 40% of global production of sugar. In Egypt, about 57 % of sugar is being produced from sugar beet. Sugar beet seeds are not produced in Egypt due to requirements in terms of temperature and sunlight. As a result, Egypt depends on seed varieties imported from Europe. The technology of synthetic seed was developed to get the advantages of seed propagation with clonal propagation and germplasm storage together.

Synthetic seed can be stored at 4°C for 12 months using shoot tips as explant of *T. pieinicum* without subculture (Kamińska et al., 2018). Synthetic seed may be considered as artificially encapsulated plant propagules i.e. shoot buds, somatic embryos, cell aggregates or any tissue of plant can be planted as a seed and have the ability to turn into whole plant at *in-vitro* or *ex-vitro* conditions, and covert again even after storage condition (Capuano et al. 1998; Ara et al. 1999). Shoot tips and axillary buds can also be used for synthetic seeds (Sarkar and Naik 1998). Combination of calcium chloride and sodium

alginate as protective coating for plant propagules result in a synthetic seed with different structure, form and translucence. The alginate coating behaves like an artificial endosperm, which enables uptake of nutrients to the explant during re-growth in optimal conditions (Ahmed et al. 2015). The synthetic seed technology has been applied commercially and various micro-propagules have been considered for artificial seed production. Somatic embryos have been used to produce artificial seeds in crops like sugar beet (Tsai and Saunders 1999), rice (Kumar et al., 2005) and groundnut (Padmaja et al., 1995). On the other hand, in many plant species, such as banana (Ganapathi et al., 1992), rose (Sharma et al., 1994), *Japanese camellia* (Ballester et al. 1997), *Common gypsophila* (Rady and Hanafy 2004) and cauliflower (Siong et al., 2012) the axillary shoot buds and apical shoot tips have been encapsulated to produce artificial seeds.

Weed control in sugar beet is more difficult and expensive than other crops due to its less competitive against weeds. Sometimes, weed competition can cause economic yield loss of up to 100 % (Brants and Harms 1998). Because of the late canopy closure and the low plant height of the crop, weeds should be controlled nearly completely, at least until the eight-leaf stage to avoid significant yield loss (Märlander 2005). We usually treated sugar beet fields several times with mixtures of herbicides during the growing season. Sugar beet is negatively influenced by the phyto-toxicity effects of many herbicides. The most critical period for weed control is within 8 weeks after emergence and timing of treatment is difficult and could yield suboptimal results. Therefore, the availability of herbicide resistant varieties could improve weed control throughout resilience in the time of application by reducing the number of application (D'Halluin et al., 1992). Lately the transgenic beet H7-1 was developed as herbicide resistance variety was commercialized in USA in 2008 and controlled sugar beet production, about 95% sugar beet plantation area in USA from H7-1 variety (Park et al., 2011). H7-1 was developed by using agrobacterium tumefactions transformation (Green 2009). Sugar beet is very hard species to response for agrobacterium. So there a few numbers of papers showed effective transformation and development of GM plants of sugar beet (Sundar and Sakthivel 2008). Therefore, the objectives of this study are to produce the synthetic seed from sugar beet using shoot tip as explants, *In vitro* germination rates and the storage ability of synthetic seed

were also evaluated, produce herbicide resistant plants using agrobacterium transformation system.

## MATERIALS AND METHODS

### Plant materials and tissue culture conditions

Sugar beet seeds cultivars (El-Magary and Farida) were kindly obtained from Sugar Crops Research Institute, Agriculture Research Center, Giza, Egypt. Sugar beet seeds were sterilized with 70% (v/v) ethanol for 1 min followed by 40% commercial clorox (5.25% sodium hypochlorite) for 20 min then rinsed with sterile distilled water several time. Seed were left in the sterile water for 16-20 h at room temperature.

The sterilized seeds were germinated in jars containing 50 ml of MS medium (Murashige and Skoog 1962), 30 g/l sucrose and 0.5 mg L-1,2,3,5-triiodobenzoic acid (TIBA). With seven to ten days further, shoot apices explant were excised and transferred to MSB medium (MS basal medium containing B5 vitamin (Gamborg 1970) and supplemented with 1mg N6-benzyl adenine (BA), 0.1 mg L-1 $\alpha$ -naphthalene acetic acid (NAA), and 0.5 mg L-1TIBA) (SIM1) for shoot induction (Mohammadzadeh et al., 2015). After two weeks further shoots were transferred to shoot induction medium 2 (SIM2) for optimal shoot development (MSB, 0.5 BA, 0.1 indole-3-butyric acid (IBA)). After more 2 weeks, shoot were transferred to fresh shoot induction medium (SIM2) for optimal shoot development. For root formation, regenerated sugar beet shoots were cultured on MS medium with 1mg/L indol-3-acetic acid (IAA). All tissue culture media were solidified with 0.7% agar, supplemented with 30 g/l sucrose and adjusted to pH 5.8 before autoclaving at 121°C and 1.5 lb/M<sup>2</sup> for 25 min. Cultures were incubated at 25  $\pm$  2°C and 16/8( light /dark)hr photoperiod. For acclimatization, *in vitro* rooted plantlets were gently washed with tap water and disinfected by soaking in topsin solution (1 g/l) for 5 min. Then plantlets were transferred to plastic pots containing sterile 1,1,1 (bitmos, clay, sand). The pots were covered with transparent polyethylene bags containing a few pores to allow gas exchange and sprayed with water to maintain a high relative humidity. Covers were completely removed after seven to ten days.

### Artificial Seeds Preparation

Encapsulation was accomplished by mixing the shoot tip explants with the alginate and dropping these into the Ca (NO<sub>3</sub>)<sub>2</sub>·4H<sub>2</sub>O solution.

Individual shoot tip explants were coated in sodium alginate solution by transferring them into either SA1 solution (MS, 3% sucrose, 4% sodium alginate, 2% sorbitol and 2% mannitol) or SA2 solution (MS, 3% sucrose, 1.3 BAP, 4% sodium alginate, 2% sorbitol and 2% mannitol). The droplets of sodium alginate solution containing one shoot tip each were then slowly dropped into 100 mM Ca (NO<sub>3</sub>)<sub>2</sub>·4H<sub>2</sub>O solution and stirred continuously for at least 30 min on a stirrer to achieve polymerization. Beads were collected and rinsed with sterile distilled water to wash away Ca (NO<sub>3</sub>)<sub>2</sub>·4H<sub>2</sub>O residues. Coated explant were placed in petri dishes and incubated at dark for 1,2,4,8 weeks at 4°C.

The artificial seeds were then cultivated in a germination medium (MS medium with 0.5 mg/l BA and 0.5 mg B5 vitamin) (Ismail et al., 2016). They were then kept left in the culture chamber at 4°C incomplete darkness to slow growth; data were taken after 6 weeks.

### Sensitivity to Selection Agent (Survival Curve)

Shoot tip explants were excised from seedling and cultured on SIM1 supplemented with different concentrations of Bialaphos ;( 0.0, 1.0, 2.0, 3.0 and 4.0 mg/L) (Dovzhenko and Koop 2003). After three weeks, the concentration of Bialaphos, which kill all shoot tips explants, was used as a selection agent.

### Agrobacterium strain and plasmids

*Agrobacterium tumefaciens* LBA4404 strain (Horsch et al. 1985) carrying plasmid pISV2678 that harboring gus-intron under the control of CaMV 35S promoter and nos terminator as well as bar gene under the control of nos promoter, AMV leader and pAg7 terminator, provided by Dr. P. Ratet, ISV, CNRS, Gif-Sur-Yvette, France figure (1), was used in the transformation experiment.

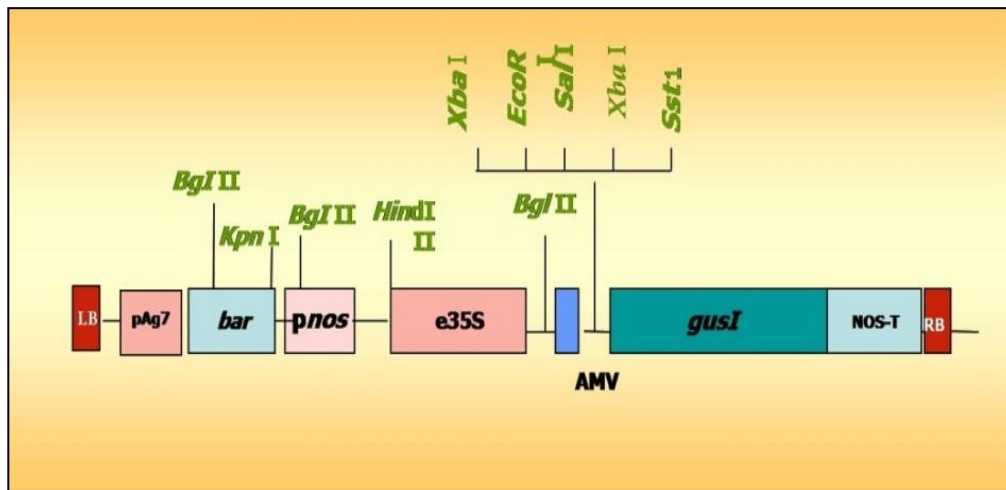

Figure (1): A diagram showing the map of pISV2678 plasmid

*Agrobacterium* was cultured for 2 days at 28°C on a rotary shaker at 180 rpm in liquid kanamycin LB medium. The grown bacterial cells were transferred to 50 ml of LB liquid medium for 3-4 hours at 150 rpm until an OD<sub>600</sub> nm of 0.6–0.7. After that, bacterial cultures were centrifuged at 3500 rpm at 4 °C for 10 min and pellets were re-suspended in liquid MS medium before co-cultivation with explants to obtain a final OD<sub>600</sub> nm of about 0.3 (Chilton et al. 1974; Mishutkina et al. 2010).

Shoot tip explants were emerged in the *agrobacterium* culture for 10 min and exceed

liquid was removed by placing the explants on sterilized filter paper. Shoot tip explants were then transferred to SIM1 medium for two days. Thereafter, the explants were rinsed with sterilized distilled water supplemented with 0.1 mg/l cefotaxime to remove the remaining traces *Agrobacterium* from the surface of explants and then transferred to selection medium (SIM1+ Bialaphos + 500mg/l cefotaxime).

### Transformation procedure

Sugar beets of cultivars i.e, El-Magary and Farida were transformed by LBA4404 strain

carrying plasmid pISV2678. Plants were transformed as described by (Norouzi et al., 2005; Mohammadzadeh et al., 2012).

### Evaluation of sugar beet plant

#### Histochemical assay

After *Agrobacterium transformation*, GUS-assay detection was carried out for detect the expression of GUS gene according to (Jefferson et al. 1987). Two days sugar beet explants were immersed in 1 mL GUS buffer and rapped with aluminum foil, to prevent light effect. The samples were then incubated for 12 h on a rotary shaker (150 rpm) at 37°C for color development. To inhibit plant endogenous GUS activity, the buffer was removed and 70% ethanol was added.

#### Bar-gene detection

In order to detect the presence of the bar-gene, PCR analysis was performed into genomic DNA that extracted from the plant leaves using DNeasy Kit (Qiagen). PCR primers specific to the bar-gene, 5'AAAAGCTTCCACCATGAGCCAGA ACGACG-3'(Fw) and 5'AAGGATCCTCAGATCT CGGTGACGG-3'(Rw) were used.

#### Herbicide resistance tests

Putatively transgenic sugar beet plants were detected by the leaf painting assay. A concentration of 2 g/l of basta herbicide was used for painting sugar beet leaves transgenic and non-transgenic. Ten days after application, leaves of control plants showed chlorosis or necrosis, whereas, transgenic plants were showed a mild toxic reaction.

Sugar beet plants that were grown in pots and treated with 2 g/l basta herbicide were harvested

6 months old age and growth traits viz., root length, root diameter, root weight, shoot weight and leaf area (using leaf area meter) were measured. Total chlorophylls content was measured using chlorophyll meter, model SPAD-502 in which SPAD unit = 10mg/100g fresh weight of leaves (Netto et al., 2005). Total soluble solids (TSS) were determined by using digital refractometer model PR-1, ATAGO, Japan. Sucrose percentage was determined by using saccharometer lead acetate extract of fresh moderated roots according to (Carruthers and Oldfield 1961). Purity was calculated by dividing sucrose % by TSS.

#### RAPD-PCR analysis

A set of 13 primers RAPD table (1) were used to detection the polymorphism. The amplification reaction was carried out in 25 µl reaction volume containing 1X PCR buffer, 1.5 mM MgCl<sub>2</sub>, 0.2 mM dNTPs, 1 µM primer, 1 U Taq DNA polymerase and 30 ng template DNA (Mokhtar et al., 2016). The PCR program was 40 cycles after an initial denaturation cycle for 5 min at 94°C. Each cycle consisted of a denaturation step at 94°C for 1 min, an annealing step at 36°C for 1 min, and an elongation step at 72°C for 1.5 min. The primer extension segment was extended to 7 min at 72°C in the final cycle. The amplification products were resolved by electrophoresis in a 1.5% agarose gel containing ethidium bromide (0.5µg/ml) in 1X TBE buffer at 95 volts. A 1kb DNA ladder was used as a molecular size standard. PCR products were visualized on UV light and photographed using a Gel Documentation System (BIO-RAD 2000).

**Table (1): The sequence of RAPD primers**

Primer Name	Primer Sequence	Primer Name	Primer Sequence
C7	GTCCCGACGA	C19	GTTGCCAGCC
C9	CTCACCGTCC	C20	ACTTCGCCAC
C10	TGTCTGGGTG	G1	CTACGGAGGA
C11	AAAGCTGCCGG	G2	GGCACTGAGG
C16	CACACTCCAG	O1	GGCACGTAAG
C17	TTCCCCCAG	O5	CCCAGTCACT
C18	TGAGTGGGTG		



## RESULTS AND DISCUSSION

### Synthetic seed viability as affected by storage treatments

Synthetic seeds are defined as encapsulated embryos, shoots, buds, cell aggregates, or any other tissue that can be used as a seed that possess the ability to convert into a plant under *in vitro* or *ex-vitro* conditions can retain after storage (Magray et al., 2017). Germplasm can be effectively stored in the form of synthetic seeds that offer several advantages, easy handling, store ability, reduced size of propagules, and transport ability (Rizkalla et al., 2012).

The present study illustrates the implementation of synthetic seed technology for mass propagation and short-term storage of sugar beet (El-Magary and Farida) plants. Shoot tip explants were used to develop synthetic seed, by using SA1 and SA2 coating media and storing for 1, 2, 4, 8 weeks at 4°C. To determine the synthetic seeds viability after storage periods, synthetic seed were germinated on SIM1 medium table (2).

Results showed that prolongation of storage period more than one week significantly reduced germination percentage of synthetic seeds of both cultivars and coated media. Germination percentage of synthetic seeds cv. El-Magary coated with SA1 medium reduced from 100 to 60, 20 and 20 when storage periods were 1, 2, 4 and 8 weeks, respectively. However, it reduced from 80 to 60, 60 and 40 when storage periods were 1, 2, 4 and 8 weeks, respectively in case of SA2 coated medium. On the other hand, germination percentage of synthetic seeds cv. Farida coated with SA1 medium reduced from 100 to 60, 60 and 0 when storage periods were 1, 2, 4 and 8 weeks, respectively. However, it reduced from 100 to 80, 40 and 20 when seeds storage periods were 1, 2, 4 and 8 weeks, respectively in the case of SA2 coated medium. Thus SA2 coated medium was better than SA1 medium as it preserved the seed

**Table (2): Percentage of synthetic seed germination as affected by Storage media and storage period of sugar beet varieties El-Magary and Farida.**

Storage media	Storage period	% Germination	
		El-Magary	Farida
SA1	1week	100%	100%
	2week	60%	60%
	4week	20%	60%
	8week	20%	0%
SA2	1week	80%	100%
	2week	60%	80%
	4week	60%	40%
	8week	40%	20%

viability to 40% in El-Magary and 20 % in Farida cv. after 2 months storage table (2) and figure (2).

In the present investigation coated medium was contained mannitol and sorbitol for enhancing the viability of synthetic seeds after long storage period because they work as osmotic agents which increase plantlet survival when adding to the medium (Lata et al., 2010). Agreement with our results Rizkalla et al., (2012) and Nower, (2014) reported that the culture survival was increased due to addition of mannitol and/ or sorbitol to the medium, in *Podophyllum peltatum*, sugar beet and *Stevia rebaudiana*. On the other hand, (Ismail et al., 2016) reported that the germination percentage of synthetic seeds of Farida cv. decreased to 20% in 8 weeks storage time when they used the same coated medium without the mannitol and sorbitol. Therefore, sorbitol and mannitol are considered important factor in coated storage medium.

Cold temperature is the most efficient way in cell slowdown growth (Kamińska et al., 2018). Chand and Singh (2004) were previously reported that 4°C is the most suitable method for storage many species for long time. The difference between Farida and El-Magary cv in its seeds viability after storage indicating the genotype effect. This agrees with Gurel (1997) who stated that sugar beet heterozygous, it is reasonable large inter-variety variation exists.

### Survival curve

Bialaphos is a natural and a non-selective herbicide produced by the bacteria *Streptomyces hygroscopicus* and it is made up of two alanine residues and glufosinate. Bialaphos is used as a gene selector in plants transformed by bar gene confers resistance to Bialaphos. Farida and El-Magary cultivars were cultured in SIM1 medium containing (0, 0.5, 1, 1.5, 2, 2.5, 3, 3.5 and 4mg/l of Bialaphos). Results showed that cells did not grow in 3.5µg/ml for Farida and 4µg/ml for El-Magary figure (3).

(SA1): MS, 3% sucrose, 4% sodium alginate, 2% sorbitol and 2% mannitol  
 (SA2): MS, 3% sucrose, 1.3 BAP+4% sodium alginate, 2% sorbitol and 2% mannitol

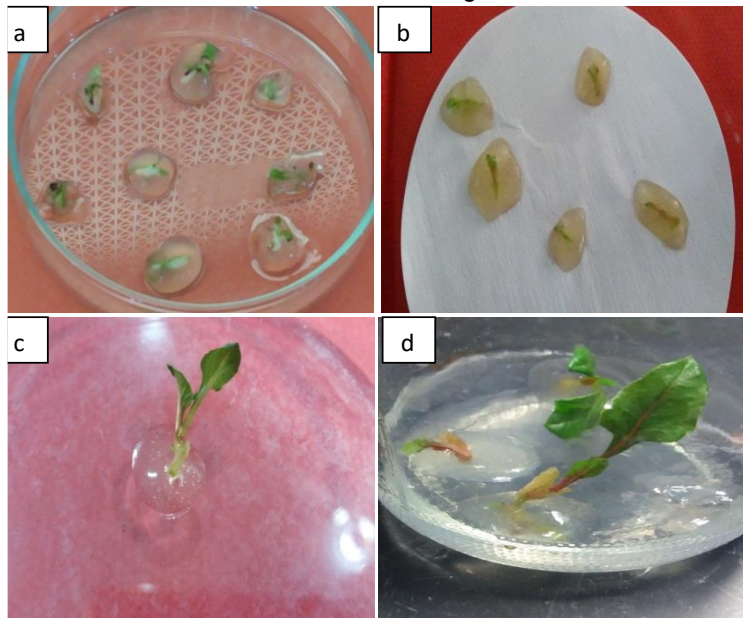

Figure (2): Encapsulated shoot tips and regeneration of synthetic seed. (a, b) coated shoot tip with alginate/agar (c, d) germinated of synthetic seeds after 2 weeks on MS medium.

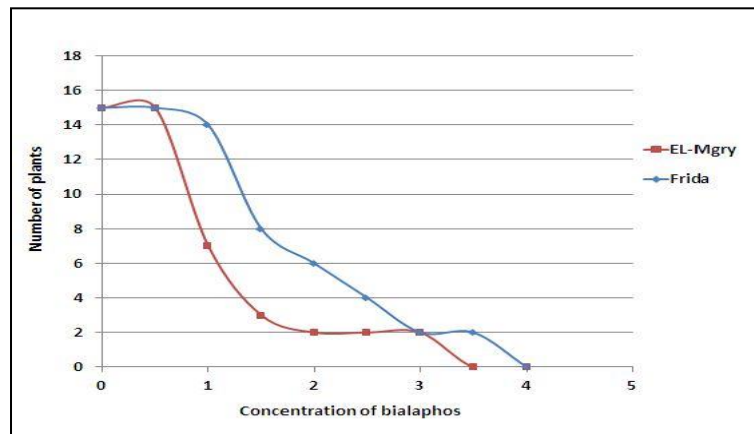

Figure (3): Number of survived ex-plants of El-Magary and Frida varieties under different concentrations of Bialaphos.

experiments.

### Agrobacterium-mediated transformation of sugar beet plants

Agrobacterium-mediated transformation used to enhance sugar beets tolerance to either nonselective, broad-spectrum herbicides (i.e., active ingredient of Roundup®, glyphosate, active ingredient of Basta®, glufosinate, and Herbiace®) or selective herbicides (chlorsulfuron, imidazolinone and sulfonyleurea) (Gurel et al., 2008). In this investigation shoot tips of developed plantlet were used as explants for transformation

Agrobacterium-mediated transformation of sugar beet plants using shoot tips as explants has been reported (Lindsey and Gallois 1990; Konwar 1994; Hisano et al., 2004). To select the best time for co-cultivation, ten explants of each cultivar were co-cultivated with *Agrobacterium tumefaciens* strain LB4404 harboring pLSV2678 in different time (5, 10, 15 and 20 minute) and cultured on SIM1 medium. Survived explants were observed three days further table (3).

**Table (3): The effect of co-cultivation time on explants in both cultivars**

Cultivar	Co-cultivated time( minute)	Percentage of survival explants
<b>EI-Magary</b>	5	100%
	10	100%
	15	90%
	20	70%
<b>Farida</b>	5	100%
	10	100%
	15	90%
	20	60%

Five or ten minutes were revealed the suitable co-cultivation times due to the highest percentage of survival explant (100%). Then, explants were transferred to SIM2 medium (MSB , 0.5 mg/l BA, 0.1 mg/l IBA, 500 mg /l cefotaxime and 3.5, 4 mg/ l Bialaphos for Farida and EI-Magary respectively. A number of 6 and 9 plants were obtained out of 40 Agrobacterium treated explants representing a percentage of transformation efficiency 15 and 22.5 in Farida and EI-Magary in respect. Obtained plants survived and developed a functional root

system on MS medium containing 1 mg/l IBA, 500 mg /l cefotaxime and 3.5, 4 mg/ l Bialaphos as a selective rooting medium. After 4-6 weeks rooted plants were successfully acclimatization in soil under greenhouse conditions figure (4).

#### Histochemical GUS assay

For study the GUS activity, tissues of obtained sugar beet plants were incubated with GUS buffer for 48 h figure (5). All tested tissues were changed into blue indicating the GUS gene expression.

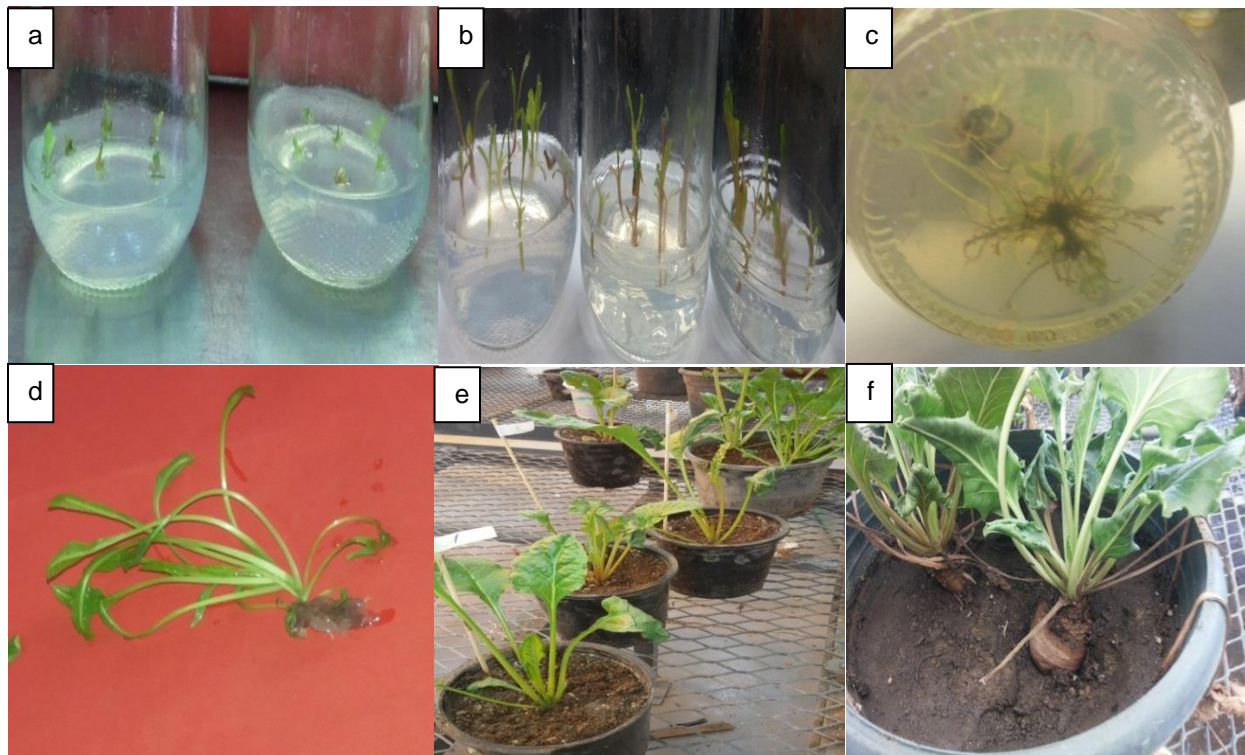

**Figure (4): The process of developed transformed sugar beet plants: (a) transferred shoots tip; (b) transferred shoot tips after two weak; (c) root formation; (d) plant prepare for acclimation; (e) plant adaptation in green house; (f) final stage.**





**Figure (5): GUS assay of shoot tip explants transformed with *Agrobacterium tumefaciens* LBA4404, contain plasmid (pISV).**

#### Evaluation of transformed plant

A total of 13 plants for each cultivar were subject to the PCR test to confirm the presence of the transgene. Results of PCR reactions carried out using primers specific to the Bar-gene, cleared that the percentage of transformed explants were 18%, 12% of El-Magary and Farida respectively. Amplified fragments had expected size 540 bp figure (6).

#### Leaf painting Assay and its relation to herbicide resistance

Basta is a versatile non-selective herbicide registered for the control of over 80 weed species in a wide range of crops. Basta has a partially systemic mode of action that provides a higher level of crop safety than systemic alternatives like glyphosate (<https://crop-solutions.basf.com.au/products/basta>). Ten days after painting sugar beet plants leaves with a freshly prepared solution of the Bialaphos (0.2% v/v), leaves of non-transgenic plants (control) showed chlorosis or necrosis under the filter paper. Transgenic plants were resistant to herbicide figure (7).

#### The effect of herbicide basta on transgenic sugar beet plants

Data presented in table (4) revealed that

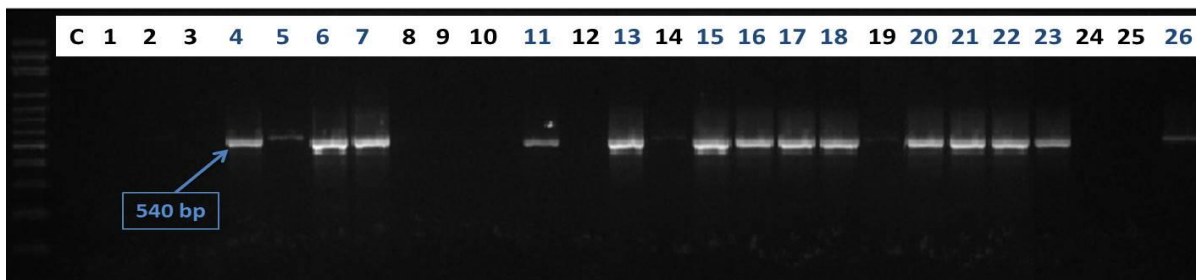

**Figure (6): PCR analysis of transgenic sugar beet plants for Bar-gene by specific primer. First lane represent 100bp DNA ladder, lane C referred to control plant, lane from 1 to 13 represent Farida and 14 to 26 represent El-Magary cultivar.**

spraying herbicide resistant sugar beet plants with basta had no significant effect on growth traits in terms of root length, root diameter, root weight, shoot weight and leaf area in both cultivars. Also total chlorophyll content was not affected significantly with spraying of basta. Quality traits in terms of total soluble percentage, sucrose percentage and purity were decreased significantly by spraying sugar beet plants with Basta herbicide in both cultivars. Similar result was reported by Majidi et al., (2017) who found that Spraying sugar beet plants with broadleaf herbicides affected significantly on sucrose percentage.

#### RAPD analysis

RAPD analysis was performed to verify the genetic stability of transformed plantlets after acclimatization. In the total 13 RAPD primers were used to screening and compering DNA sample of controls, herbicide resistant and plants developed from synthetic seeds for both cultivars. The size of amplified fragments ranged from 50 to 2000 bp and both herbicide resistant and synthetic seeds were genetically similar to the control figure (8).





Figure (7) Non-transgenic and transgenic sugar beet plants as affected by leaf painting assay. Left pot represents control plant and right pot represents herbicide-resistant plant.

Table (4): Some agronomic traits of two sugar beet varieties as affected by Basta herbicide in non-treated (control) and treated herbicide resistant plants.

Character	EI-Magyar		Farida	
	Control	Transgenic	Control	Transgenic
Root weight (g)	486.00a+	460.00a	372.00a	326.00a
Shoot weight (g)	303.00a	313.00a	225.00a	221.00a
Leaf area/plant (cm <sup>2</sup> )	325.12a	337.05a	314.60a	286.50a
Total Chlorophyll (SPAD-502)	41.30a	37.50a	35.00a	30.20a
Root length (cm)	34.00a	28.00a	26.00a	22.00a
Root diameter (cm)	18.00a	16.00a	15.00a	12.00a
TSS %	18.90a	17.35b	18.30a	16.55b
Sucrose %	16.60a	14.30b	15.00a	13.80b
Purity %	87.83a	82.42b	81.97a	83.38b

+ different litters denote significant difference between treated and non- treated plants

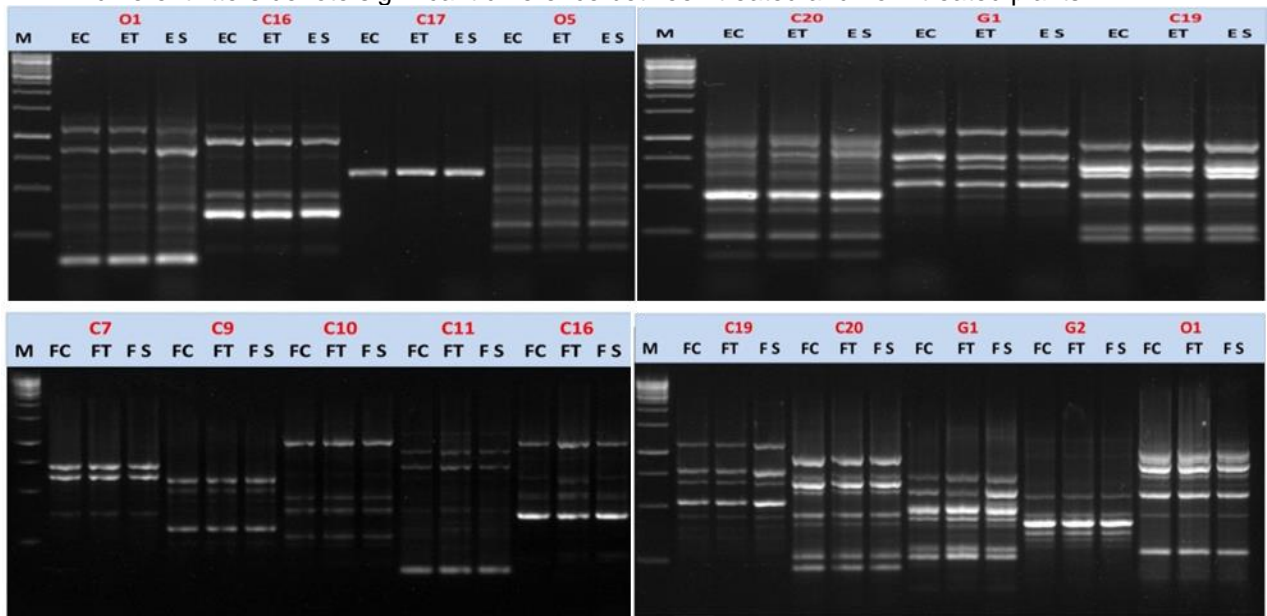

Figure (8): RPAD-PCR analysis of 13 primers against controls (C), herbicide resistant (T), plants developed from synthetic seeds, (S) for both cultivars Farida (F) and EI-Magyar (E); (M) 1kb DNA ladder.

It is considered that the shoot tips are the stable genetically, in turn, high probability of genetic change occurs in callus and protoplast culture and it consistent with other previously published reports by (Lindsey and Gallois 1990; Hisano et al. 2004; Krishna et al., 2016). Our results also showed that the storage does not produce genetic variation at the resolution provided by the RAPD analysis and it consistent with reports of genetic stability of stored synthetic seed derived plants of *Ananus comosus* after 2 months at 8°C (Gangopadhyay et al., 2005) and for 12 months at 4 °C (Kamińska et al., 2018)

### CONCLUSION

Our study enabled to established herbicide resistant's sugar beet plants and producing genetically sustainable synthetic seeds of sugar beet shoot tips. Applied conditions provide a promising, cost-effective and time-saving method. Successful plant retrieval from synthetic seeds following 2-months storage at 4 °C indicates that protocol described in this paper could be used to long-term preservation of the sugar beet germplasm.

### CONFLICT OF INTEREST

The authors declared that present study was performed in absence of any conflict of interest.

### AUTHOR CONTRIBUTIONS

All authors contributed equally to this work

**Copyrights: © 2019 @ author (s).**

This is an open access article distributed under the terms of the [Creative Commons Attribution License \(CC BY 4.0\)](https://creativecommons.org/licenses/by/4.0/), which permits unrestricted use, distribution, and reproduction in any medium, provided the original author(s) and source are credited and that the original publication in this journal is cited, in accordance with accepted academic practice. No use, distribution or reproduction is permitted which does not comply with these terms.

### REFERENCES

- Ahmed MR, Anis M, Al-Etta HA, 2015. Encapsulation technology for short-term storage and germplasm exchange of *Vitex trifolia* L. *Rend Lincei* 26:133–139.
- Ara H, Jaiswal U, Jaiswal VS, 1999. Germination and plantlet regeneration from encapsulated somatic embryos of mango (*Mangifera indica* L.). *Plant Cell Rep* 19:166–170.
- Ballester A, Janeiro LV, Vieitez AM, 1997. Cold

storage of shoot cultures and alginate encapsulation of shoot tips of *Camellia japonica* L. and *Camellia reticulata* Lindley. *Sci Hortic (Amsterdam)* 71:67–78.

- Brants I, Harms H, 1998. Herbicide tolerant sugar beet. In: *Comptes-Rendus des Congres de l'Institut International de Recherches Betteravieres (Belgium)*.
- Capuano G, Piccioni E, Standardi A, 1998. Effect of different treatments on the conversion of M. 26 apple rootstock synthetic seeds obtained from encapsulated apical and axillary micropropagated buds. *J Hortic Sci Biotechnol* 73:289–297.
- Carruthers A, Oldfield JFT, 1961. Methods for the assessment of beet quality. *Int Sugar J* 63:72–74.
- Chand S, Singh AK, 2004. Plant regeneration from encapsulated nodal segments of *Dalbergia sissoo* Roxb., a timber-yielding leguminous tree species. *J Plant Physiol* 161:237–243.
- Chilton M, Currier TC, Farrand SK, Bendich AJ, Gordon MP, Nester EW, 1974. *Agrobacterium tumefaciens* DNA and PS8 bacteriophage DNA not detected in crown gall tumors. *Proc Natl Acad Sci* 71:3672–3676.
- Dovzhenko A, Koop HU, 2003. Sugarbeet (*Beta vulgaris* L.): shoot regeneration from callus and callus protoplasts. *Planta* 217:374–381. doi: 10.1007/s00425-003-1006-7
- Gamborg OL, 1970. The effects of amino acids and ammonium on the growth of plant cells in suspension culture. *Plant Physiol* 45:372–375.
- Ganapathi TR, Suprasanna P, Bapat VA, Rao PS, 1992. Propagation of banana through encapsulated shoot tips. *Plant Cell Rep* 11:571–575.
- Gangopadhyay G, Bandyopadhyay T, Poddar R, Gangopadhyay SB, Mukherjee KK, 2005. Encapsulation of pineapple micro shoots in alginate beads for temporary storage. *Curr Sci* 972–977.
- Green JM, 2009. Evolution of glyphosate-resistant crop technology. *Weed Sci* 57:108–117.
- Gurel E, 1997. Callus and root development from leaf explants of sugar beet (*Beta vulgaris* L.): Variability at variety, plant and organ level. *Turk J Botany* 21:131–136.
- Gurel E, Gurel S, Lemaux PG, 2008. Biotechnology applications for sugar beet. *CRC Crit Rev Plant Sci* 27:108–140.
- D'Halluin K, Bossut M, Bonne E, Mazur B,

- Leemans J, Botterman J, 1992. Transformation of Sugarbeet (*Beta vulgaris* L.) and Evaluation of Herbicide Resistance in Transgenic Plants. *Bio/Technology* 10:309–314. doi: 10.1038/nbt0392-309
- Hisano H, Kimoto Y, Hayakawa H, Takeichi J, Domae T, Hashimoto R, Abe J, Asano S, Kanazawa A, Shimamoto Y, 2004. High frequency Agrobacterium-mediated transformation and plant regeneration via direct shoot formation from leaf explants in *Beta vulgaris* and *Beta maritima*. *Plant Cell Rep* 22:910–918.
- Horsch RB, Rogers SG, Fraley RT, 1985. Transgenic plants. In: Cold Spring Harbor Symposia on Quantitative Biology. pp 433–437
- Ismail RM, Raslan WM, Hussein GMH, 2016. *In Vitro* Propagation of Sugar Beet Cultivar Frida, Through Encapsulated Different Explants. *Am J Agric Sci* 3:27–34.
- Jefferson RA, Kavanagh TA, Bevan MW, 1987. GUS fusions: beta-glucuronidase as a sensitive and versatile gene fusion marker in higher plants. *EMBO J* 6:3901–3907.
- Kamińska M, Gołębiewski M, Tretyn A, Trejgell A, 2018. Efficient long-term conservation of *Taraxacum officinale* synthetic seeds in slow growth conditions. *Plant Cell Tissue Organ Cult* 132:469–478. doi: 10.1007/s11240-017-1343-z
- Konwar BK, 1994. Agrobacterium tumefaciens-mediated genetic transformation of sugar beet (*Beta vulgaris* L.). *J Plant Biochem Biotechnol* 3:37–41.
- Krishna H, Alizadeh M, Singh D, Chauhan N, Eftekhari M, Sadh RK, 2016. Somaclonal variations and their applications in horticultural crops improvement. *3 Biotech* 6:54.
- Kumar MBA, Vakeswaran V, Krishnasamy V, 2005. Enhancement of synthetic seed conversion to seedlings in hybrid rice. *Plant Cell Tissue Organ Cult* 81:97–100. doi: 10.1007/s11240-004-2448-8
- Lata H, Moraes RM, Bertoni B, Pereira AMS, 2010. *In vitro* germplasm conservation of *Podophyllum peltatum* L. under slow growth conditions. *Vitr Cell Dev Biol* 46:22–27.
- Lindsey K, Gallois P, 1990. Transformation of sugarbeet (*Beta vulgaris*) by Agrobacterium tumefaciens. *J Exp Bot* 41:529–536.
- Magray MM, Wani KP, Chatt MA, Ummiyah HM, 2017. Synthetic seed technology. *Int J Curr Microbiol App Sci* 6:662–674.
- Majidi M, Heidari G, Emam Y, 2017. Qualitative characteristics of sugar beet as affected by different broadleaf herbicides combinations. *Iran Agric Res* 36:1–6.
- Märländer B, 2005. Weed Control in Sugar Beet using Genetically Modified Herbicide-tolerant Varieties – A Review of the Economics for Cultivation in Europe. *J Agron Crop Sci* 191:64–74. doi: 10.1111/j.1439-037X.2004.00135.x
- Mishutkina I, Kamionskaia AM, Skriabin KG, 2010. Generation of sugar beet transgenic plants expressing bar gene. *Prikl Biokhim Mikrobiol* 46:89–95.
- Mohammadzadeh R, Zamani M, Motallebi M, Norouzi P, Jourabchi E, Benedetti M, De Lorenzo G, 2012. Agrobacterium tumefaciens-mediated introduction of polygalacturonase inhibiting protein 2 gene (PvPGIP2) from *Phaseolus vulgaris* into sugar beet (*Beta vulgaris* L.). *Aust J Crop Sci* 6:1290.
- Mohammadzadeh R, Motallebi M, Zamani M, Jahromi ZM, Norouzi P, Benedetti M, 2015. Generation of transgenic sugar beet (*Beta vulgaris* L.) overexpressing the polygalacturonase inhibiting protein 1 of *Phaseolus vulgaris* (PvPGIP1) through Agrobacterium-mediated transformation. *Turkish J Agric For* 39:429–438.
- Mokhtar MM, Adawy SS, El-Assal SS, Hussein EHA, 2016. Genic and Intergenic SSR Database Generation, SNPs Determination and Pathway Annotations, in Date Palm (*Phoenix dactylifera* L.). *PLoS One* 11:e0159268. doi: 10.1371/journal.pone.0159268
- Murashige T, Skoog F, 1962. A revised medium for rapid growth and bio assays with tobacco tissue cultures. *Physiol Plant* 15:473–497.
- Netto AT, Campostrini E, de Oliveira JG, Bressan-Smith RE, 2005. Photosynthetic pigments, nitrogen, chlorophyll a fluorescence and SPAD-502 readings in coffee leaves. *Sci Hortic (Amsterdam)* 104:199–209. doi: https://doi.org/10.1016/j.scienta.2004.08.013
- Norouzi P, Malboobi MA, Zamani K, Yazdi-Samadi H, 2005. Using a competent tissue for efficient transformation of sugarbeet (*Beta vulgaris* L.). *Vitr Cell Dev Biol* 41:11–16.
- Nower AA, 2014. *In Vitro* Propagation and Synthetic Seeds Production: An Efficient Methods for *Stevia rebaudiana* Bertoni. *Sugar Tech* 16:100–108. doi: 10.1007/s12355-013-0228-7

- Padmaja G, Reddy LR, Reddy GM, 1995. Plant regeneration from synthetic seeds of groundnut, *Arachis hypogaea* L. Indian J Exp Biol 33:967–971.
- Park J, McFarlane I, Phipps R, Ceddia G, 2011. The impact of the EU regulatory constraint of transgenic crops on farm income. N Biotechnol 28:396–406.
- Rady MR, Hanafy MS, 2004. Synthetic seed technology for encapsulation and regrowth of *in vitro*-derived *Gypsophila paniculata* L. shoot-tips. Arab J Biotech 7:251–264.
- Rizkalla AA, Badr-Elden AM, Ottai MES, Nasr MI, Esmail MN, 2012. Development of artificial seed technology and preservation in sugar beet. Sugar Tech 14:312–320.
- Sarkar D, Naik PS, 1998. Synseeds in potato: an investigation using nutrient-encapsulated *in vitro* nodal segments. Sci Hortic (Amsterdam) 73:179–184. doi: [https://doi.org/10.1016/S0304-4238\(97\)00146-5](https://doi.org/10.1016/S0304-4238(97)00146-5)
- Sharma TR, Singh BM, Chauhan RS, 1994. Production of disease-free encapsulated buds of *Zingiber officinale* Rosc. Plant Cell Rep 13:300–302.
- Siong PK, Mohajer S, Taha RM, 2012. Production of artificial seeds derived from encapsulated *in vitro* micro shoots of cauliflower, *Brassica oleracea* var. Botrytis. Rom Biotechnol Lett 17:7549–7556.
- Sundar IK, Sakthivel N, 2008. Advances in selectable marker genes for plant transformation. J Plant Physiol 165:1698–1716. doi: <https://doi.org/10.1016/j.jplph.2008.08.002>
- Tsai CJ, Saunders JW, 1999. Encapsulation, germination, and conversion of somatic embryos in sugar beet. J sugar beet Res 36:11–32.